

Z4GP20AH THRU Z4GP20MH

● **FEATURES**

- * Halogen-free type
- * Internal structure with GPRC (glass passivated rectifier chip) inside
- * Compliance to RoHS product
- * Lead less chip form, no lead damage
- * Low power loss, High efficiency
- * High current capability

● **APPLICATION**

- * AC/DC Power Supply
- * Communication Equipment

● **MECHANICAL DATA**

Case : Packed with FRP substrate and epoxy underfilled
Terminals : Pure Tin plated (Lead-Free), solderable per MIL-STD-750, Method 2026.
Polarity : Laser marking symbols
Weight : 0.11 gram

● **PACKING**

- * 5,000 pieces per 13" (330mm ± 2mm) reel
- * 2 reels per box
- * 5 boxes per carton

● **OUTLINE DIMENSIONS**

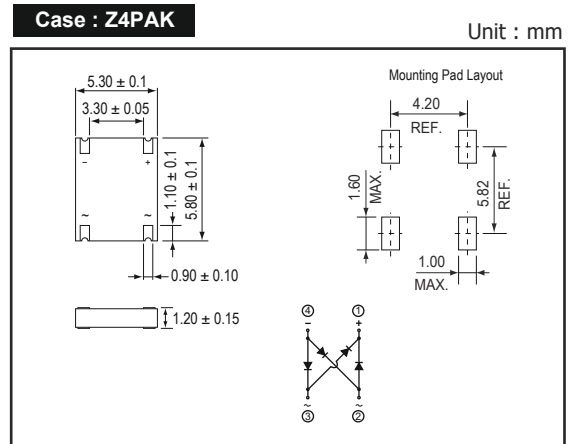

● **MARKING**

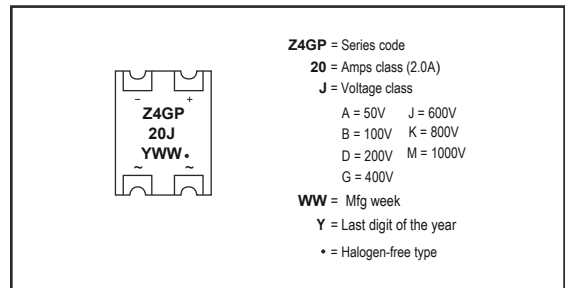

Absolute Maximum Ratings (Ta = 25°C)

ITEM	Symbol	Conditions	Z4GP20							Unit
			AH	BH	DH	GH	JH	KH	MH	
Repetitive peak reverse voltage	VRRM		50	100	200	400	600	800	1000	V
Average forward current	IF(AV)		2.0							A
Peak forward surge current	IFSM	8.3ms single half sine-wave 1.0ms Square Wave	50 105							A
Operating junction and storage temperature Range	Tj,TSTG		-55 to +175							°C

Electrical characteristics (Ta = 25°C)

ITEM	Symbol	Conditions	Min.	Typ.	Max.	Unit
Forward voltage	V _F	I _F = 2.0A	-	0.95	1.00	V
Repetitive peak reverse current	I _{RRM}	V _R = Max. VRRM, Ta = 25°C	-	0.08	5	uA
Current squared time	I ² t	t < 8.3ms, Ta = 25°C	-	10.4	-	A ² s
Junction capacitance	C _j	V _R = 4V, f = 1.0 MHz	-	25	-	pF
Thermal resistance	R _{th(JA)}	Junction to ambient (NOTE)	-	95	-	°C/W
	R _{th(JL)}	Junction to lead (NOTE)	-	15	-	

NOTE : Thermal resistance, junction to ambient, measured on PC board with 5.0 x 5.0mm (0.03mm thick) land areas.

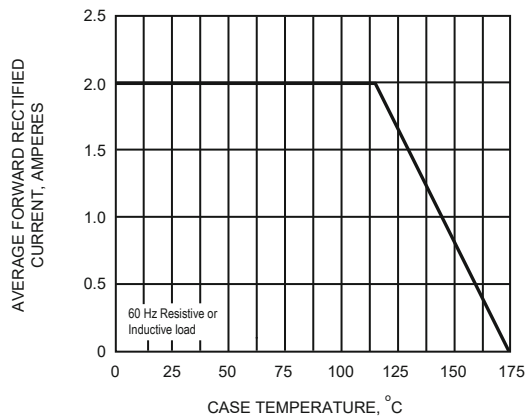
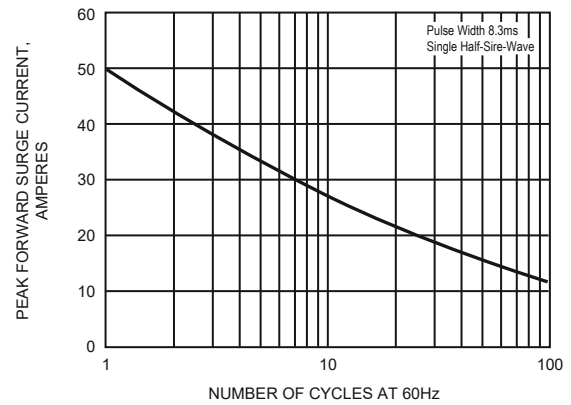
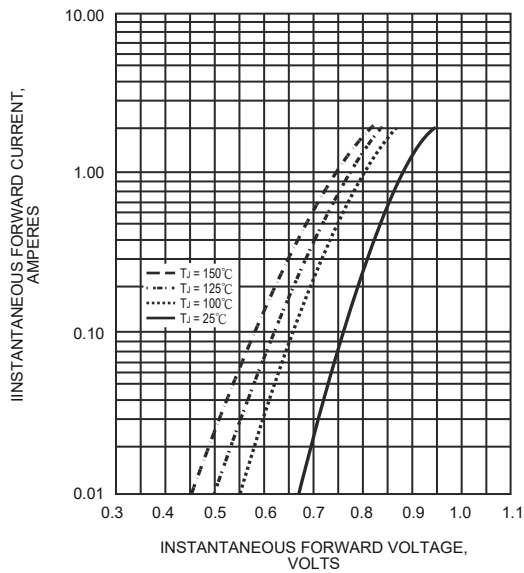
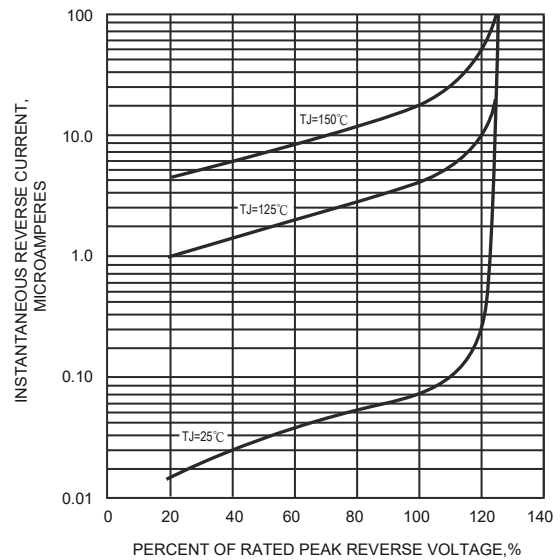
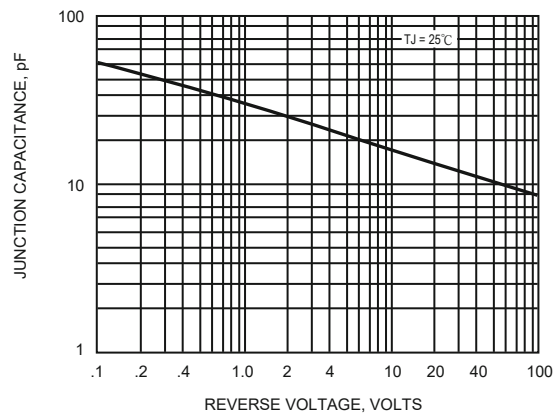
FIG.1 - FORWARD CURRENT DERATING CURVE

FIG.2 - MAXIMUM NON-REPETITIVE PEAK FORWARD SURGE CURRENT

FIG.3 - TYPICAL INSTANTANEOUS FORWARD CHARACTERISTICS

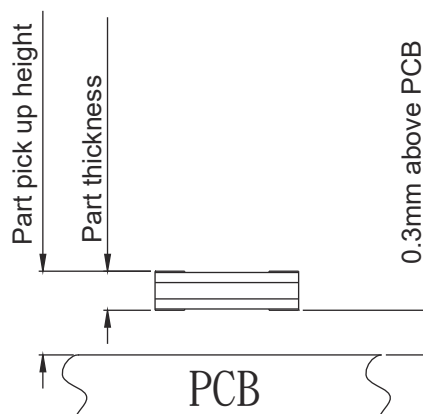
FIG.4 - TYPICAL REVERSE CHARACTERISTICS PER BRIDGE ELEMENT

FIG.5 - TYPICAL JUNCTION CAPACITANCE

● DESIGN AND MOUNTING FOR SURFACE MOUNT DIODES

1. In designing steps regarding PCB component layout, do not put surface mount device diodes near high voltage resistors etc, which may generate heat to diode, nor in high-density board. when designing the PCB, implement protection for the surface mount device diode from electrical damage like surge, heating source, magnetic and so on.
2. In any cases do not store diodes in the following conditions or places:
 - 2.1 When transporting diodes, keep vibration to a minimum otherwise body of diode may be broken. Diode die may then be destroyed by electrostatics.
 - 2.2 High temperature or high humidity environment.
 - 2.3 Where corrosive gas or liquid is present.
 - 2.4 Where mechanical stress or vibration exists.
 - 2.5 Where electrostatic charges are possible.
3. When using the ZOWIE Super chip diodes on assembly operation. Solder paste printing process is recommended and followed by pick and place machine. Since it was designed successfully to achieve extremely thin size, so the parameters of height and location should be adjusted on pick and place machine to avoid missing of parts during operation.
4. As ZOWIE SuperChip series are the surface mount devices with the exceptionally tiny package, whose package thickness is relatively much thinner than that of the general surface mount device, so please appropriately set the parameters for the nozzle height as well as the device thickness of the pick and place machine, which would diminish mostly the very normal stress applied upon the device by the nozzle so as to keep the yield level while implementing the mounting operation.
5. The following is a schematic drawing of recommended pick-up height of the SMT parts, the bottom of part above PCB is 0.3mm. If the parts are rejected seriously, please adjust to reduce the height appropriately.



● SMT Nozzle -

We recommend using larger nozzle (for example Z4PAK product can be used nozzle size $\phi 4.0\text{mm}$) so that the nozzle can reach parts of the terminals at the top, in order to reduce the impact of the parts inside dice.

